

PRO TECH

QUICK GUIDE

BATTERY-POWERED CHAINSAW

Assembly

1. Locate a clean flat surface to work on.
2. Remove the Side Cover by turning the Lock Knob counter clockwise (**Figure 1**).
3. Check to make sure that the Chain Brake is disengaged by pulling back on the Front Damper (**Figure 2**).
4. Position the Bar Slot over the Bar Post and Pins (**Figure 3**). Ensure that the Tension Nut is fully into the Bar Tension Hole.
5. Feed the Chain onto the Sprocket and Bar with the sharp Tooth edge (on the top side of the Bar) facing forward (**Figure 4**). Start from the Sprocket and work clockwise feeding the Chain around the Bar.
6. Loosely secure the Side Cover onto the Bar Post (**Figure 5**).
7. Turn the Tensioning Knob clockwise to tension the Chain until the Chain is snug on the bottom of the Bar and the Chain can be turned easily by hand. Once the Chain Tension is set, tighten the Side Cover with the Lock Knob.

BATTERY NOTICE

- Charge battery full before first use
- Try not to charge at below 0 °C
- Compatible with +62 volt 5.0AH and 2.5AH Battery

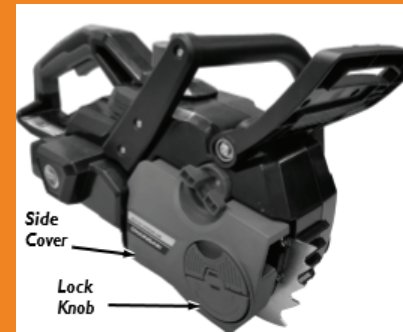

Figure 1

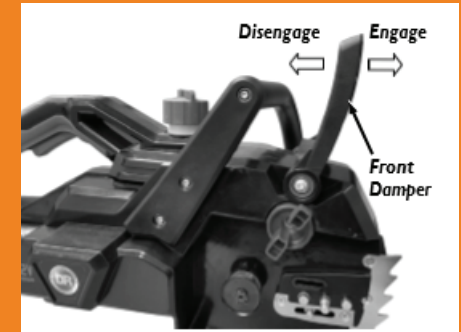

Figure 2

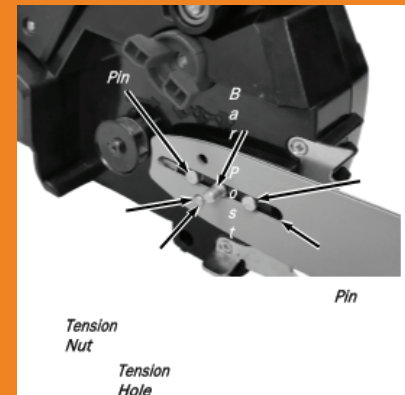

Figure 3

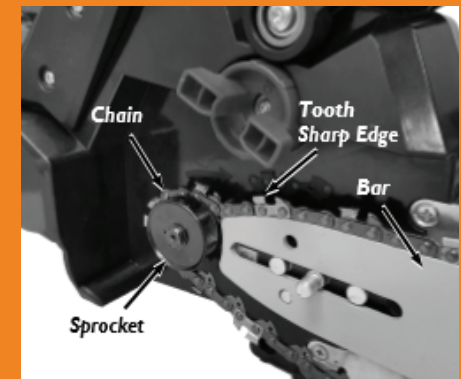

Figure 4

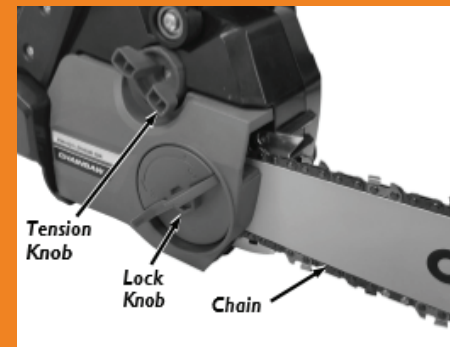

Figure 5

8. Remove the Oil Tank Cap and add #32 Bar & Chain Oil to the top line of the Oil Level Window (**Figure 6**). Replace and tighten the Oil Tank Cap.
9. Slide the Battery Pack into the Battery cradle on the Chainsaw Housing, aligning the ribs in the cradle with the slots in the Battery until it is latched into place (**Figure 7**).
10. Check that the Battery is securely locked into place.
11. To remove the Battery, press and hold the Battery Self Lock Button on the left side of the Chainsaw Housing and slide the Battery out of the Chainsaw.

How to use

1. Check to make sure that the Chain Brake is not engaged, by pulling back on the Front Damper (**Figure 2**).
2. Firmly grip the Chainsaw Auxiliary Handle with your left Hand and the Handle with your right Hand. Ensure that the Chain Is not contacting anything.
3. Press the Switch Trigger Self-Locking Button in with your thumb and squeeze the Switch Trigger with your fingers (**Figure 8**). Once the Motor starts, you can remove your thumb from the Self-locking Button. If the Motor does not start, check the Battery connection and Power Status.
4. To Stop the Chainsaw, release your fingers off the Switch Trigger.
5. Balance your weight with both feet on solid ground.
6. Keep left arm with elbow locked in a “straight arm” position to withstand any Kickback force (**Figure 9**). Your body should always be to the left of the Chain Line.



Figure 6

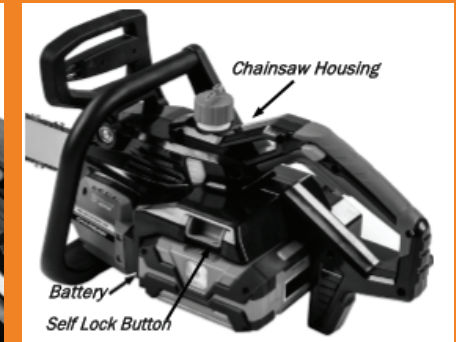

Figure 7

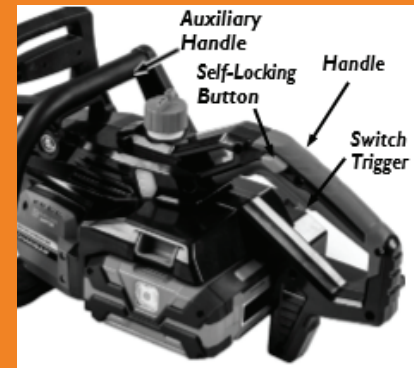

Figure 8

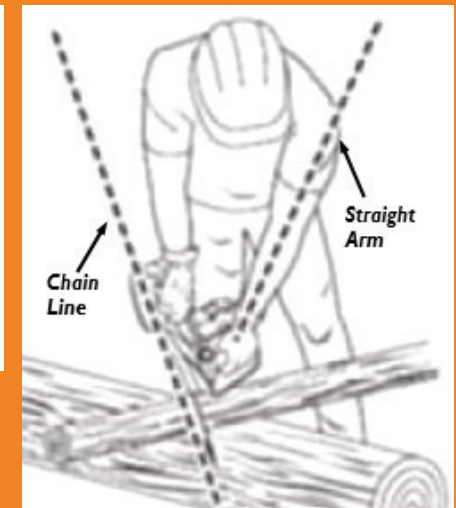

Figure 9